

For the operator

Operating instructions



vSMART

vSMART

GB, IE

Publisher/manufacture

Vaillant GmbH

Berghauser Str. 40 ■ D-42859 Remscheid
Tel. +49 21 91 18-0 ■ Fax +49 21 91 18-28 10
info@vaillant.de ■ www.vaillant.de



Contents

Contents

| | | | | | |
|----------|---|----------|-----------------------|--|-----------|
| 1 | Safety | 3 | 4.8 | Checking the battery charge condition | 10 |
| 1.1 | Action-related warnings | 3 | 4.9 | Replacing batteries | 11 |
| 1.2 | Intended use | 3 | 4.10 | Start screen | 11 |
| 1.3 | General safety information | 4 | 5 | Troubleshooting | 12 |
| 2 | Notes on the documentation | 5 | 6 | Care and maintenance | 12 |
| 2.1 | Observing other applicable documents | 5 | 6.1 | Caring for the product..... | 12 |
| 2.2 | Storing documents..... | 5 | 7 | Decommissioning | 12 |
| 2.3 | Applicability of the instructions | 5 | 7.1 | Permanently decommissioning the product..... | 12 |
| 3 | Product description | 5 | 8 | Recycling and disposal | 12 |
| 3.1 | Design of the product..... | 6 | 9 | Guarantee and customer service | 13 |
| 3.2 | Display | 6 | 9.1 | Guarantee..... | 13 |
| 3.3 | Information on the identification plate | 6 | 9.2 | Customer service..... | 13 |
| 3.4 | CE label | 7 | Appendix | 14 | |
| 4 | Operation | 7 | A | Faults – Overview | 14 |
| 4.1 | Starting up the product | 7 | B | Legal note | 14 |
| 4.2 | Preventing malfunctions | 7 | | | |
| 4.3 | Checking and setting the room temperature | 7 | | | |
| 4.4 | Installing the app..... | 8 | | | |
| 4.5 | Establishing a wireless connection | 8 | | | |
| 4.6 | Restoring the connection | 9 | | | |
| 4.7 | Comfort protection mode | 9 | | | |



1 Safety

1.1 Action-related warnings

Classification of action-related warnings

The action-related warnings are classified in accordance with the severity of the possible danger using the following warning signs and signal words:

Warning symbols and signal words

**Danger!**

Imminent danger to life or risk of severe personal injury

**Danger!**

Risk of death from electric shock

**Warning.**

Risk of minor personal injury

**Caution.**

Risk of material or environmental damage

1.2 Intended use

In the event of inappropriate or improper use, damage to the product and other property may arise.

The Vaillant vSMART controller controls a heating installation with a Vaillant boiler with eBUS interface in a way that is weather-controlled and time-dependent.

In addition, the hot water generation from a connected domestic hot water cylinder can be controlled.

Operation is permissible with the following components and accessories:

- Domestic hot water cylinder (conventional)

Intended use includes the following:

- observance of the operating instructions included for the product and any other system components
- compliance with all inspection and maintenance conditions listed in the instructions.





1 Safety

Intended use also covers installation in accordance with the IP class.

The use of the product in vehicles, such as camper vans and caravans, is not classed as intended use. Units that are not classed as vehicles are mobile homes or those that are installed in a fixed and permanent location (known as "fixed installation").

Any other use that is not specified in these instructions, or use beyond that specified in this document shall be considered improper use. Any direct commercial or industrial use is also deemed to be improper.

Caution.

Improper use of any kind is prohibited.

1.3 General safety information

1.3.1 Installation by competent persons only

Only an approved competent person is permitted to carry out installation, inspection, maintenance and repair work on the product.



1.3.2 Danger caused by improper operation

Improper operation may present a danger to you and others, and cause material damage.

- ▶ Carefully read the enclosed instructions and all other applicable documents, particularly the "Safety" section and the warnings.

Notes on the documentation 2

2 Notes on the documentation

2.1 Observing other applicable documents

- ▶ You must observe all operating instructions enclosed with the system components.

2.2 Storing documents

- ▶ Keep this manual and all other applicable documents safe for future use.

2.3 Applicability of the instructions

These instructions apply for the following only:

| Description | Article number |
|-------------|----------------|
| vSMART | 0020197226 |

3 Product description

The product controls a heating installation in a way that is weather-controlled and time-dependent using a Vaillant boiler with an eBUS interface and the hot water generation of a connected domestic hot water cylinder.

Conditions: Heating

You can use the product and associated app to set a desired temperature for a room for different times of the day and for different days of the week.

The product is a weather compensator.

The product receives the current outside temperature via the Internet connection. When the outside temperature is low, the product increases the flow temperature of the Vaillant heating installation.

If the outside temperature increases, the product lowers the flow temperature. The product therefore responds to the fluctuations in the outside temperature and uses the flow temperature to ensure that the room temperature remains constantly at the set desired temperature.

Conditions: Hot water generation

You can use the product and associated app to set the temperature and time period for the hot water generation.

The heat generator heats the water in the domestic hot water cylinder until it reaches the set temperature.

The time period defines when hot water should be ready in the domestic hot water cylinder.

3 Product description

3.1 Design of the product

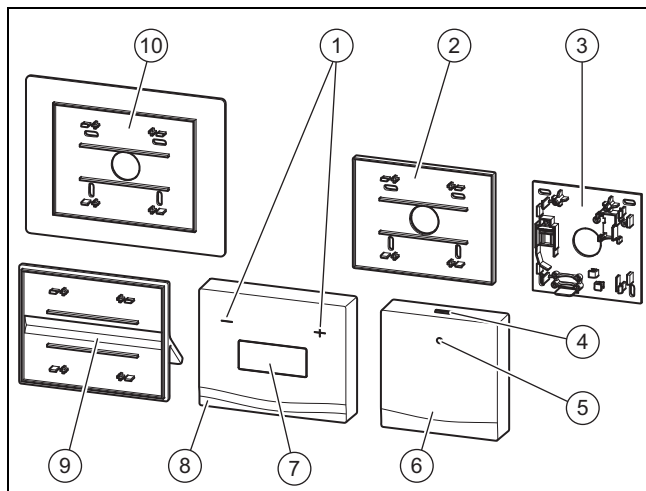

- | | | | |
|---|---|----|-------------------------------|
| 1 | buttons | 5 | Status LED |
| 2 | Small wall socket: Thermostat | 6 | Communication unit |
| 3 | Wall socket: Communication unit | 7 | Display |
| 4 | Bluetooth button/comfort protection mode button | 8 | Thermostat |
| | | 9 | Product stand |
| | | 10 | Large wall socket: Thermostat |

3.2 Display

| Symbol | Meaning |
|--------|---|
| | Connection between the thermostat and communication unit is being established |
| | Connection has been established; normal operation |
| | Connection has been broken |

3.3 Information on the identification plate

The identification plate is mounted on the rear of the communication unit and the thermostat in the factory.

| Information on the identification plate | Meaning |
|---|--|
| | Barcode with serial number (on the communication unit only), 7th to 16th digit = product article number |
| | → "CE label" section |

| Information on the identification plate | Meaning |
|---|---|
| vSMART | Product description |
| V mA | Operating voltage and current consumption |
|  | → "Recycling and disposal" section |

3.4 CE label



The CE label shows that the products comply with the basic requirements of the applicable directives as stated on the identification plate.

The declaration of conformity can be viewed at the manufacturer's site.

The manufacturer hereby declares that the type of radio equipment used in the product complies with directive 2014/53/EU. The complete text of the EU declaration of conformity can be viewed at the manufacturer's site.

4 Operation

4.1 Starting up the product

- ▶ Only start up the product once the casing has been completely closed.

4.2 Preventing malfunctions

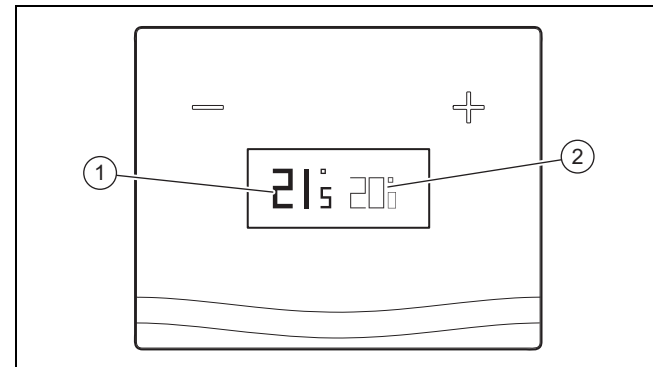

1. Ensure that the room air can freely circulate around the thermostat and that the thermostat is not covered by furniture, curtains or other objects.
2. In the rooms in which the thermostat is installed, open the radiator valves completely.

4.3 Checking and setting the room temperature



1. Check the display of the current room temperature (1) and the set target temperature (2) in the display.

4 Operation

2. If required, use the  and  buttons to set the set target temperature **(2)** to the required value.

4.4 Installing the app

1. You can use your smartphone or tablet to apply any settings beyond the basic functions.
2. Use your mobile device to download the app from <http://vsmart.vaillant.com>. Alternatively, search for **vSMART** on Google Play™ or in the App Store™.
3. Install the relevant app on your mobile device.
4. When first setting up the connection, establish a Bluetooth connection between the product and your device (→ Page 8). Configure the WLAN settings for the product via the Bluetooth connection.
5. Observe the additional instructions in the app.

4.5 Establishing a wireless connection

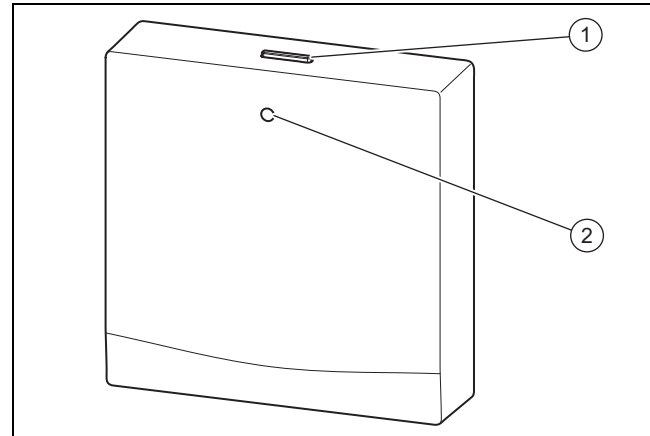

1. Activate the Bluetooth connection on your mobile device.
2. Press and hold the Bluetooth button/comfort protection mode button **(1)** on the communication unit (for at least five seconds).
 - ◁ The status LED **(2)** flashes blue on the communication unit.
3. Use the app to implement the WLAN settings. To do this, observe the instructions in the app.
 - For security reasons, only connect the product to an encrypted WLAN. Note that Wi-Fi Protected Setup (WPS) is not supported.

4.6 Restoring the connection

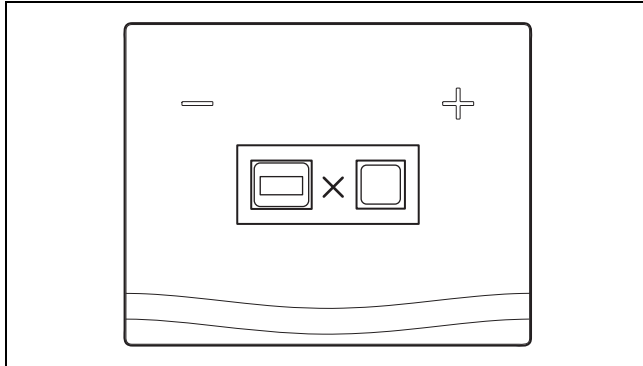

- ▶ If the above display view is shown, reduce the distance between the thermostat and the communication unit in order to restore the connection.

4.7 Comfort protection mode

If the product has no connection to the Internet, the product's operating mode cannot be set using the app.

In this case, comfort protection mode can be activated directly on the communication unit.

When comfort protection mode is activated, the room temperature is regulated to the target value that is set on the thermostat, regardless of the time periods that are set. In addition, hot water is prepared, irrespective of the set time periods.

4.7.1 Activating/deactivating comfort protection mode

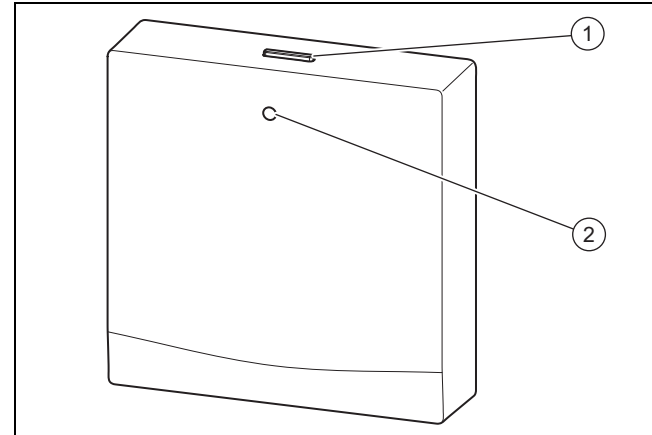



1. Press the Bluetooth button/comfort protection mode button **(1)** briefly on the communication unit.
 - You can only activate comfort protection mode if the Internet connection is interrupted.
 - ◁ The status LED **(2)** lights up blue on the communication unit.
2. Press the Bluetooth button/comfort protection mode button **(1)** again on the communication unit to deactivate the comfort protection mode.

4 Operation

- The comfort protection mode is automatically deactivated as soon as the Internet connection is re-established.

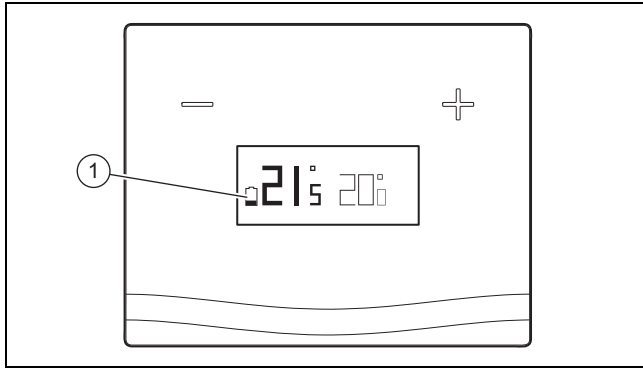
4.8 Checking the battery charge condition



If the  (1) symbol appears in the thermostat display, the batteries are almost flat.

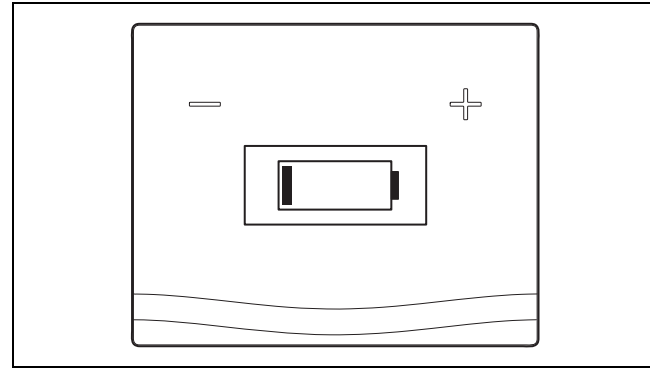

If the above display view appears on the thermostat, the batteries are flat.

- Replace the batteries in the thermostat.

4.9 Replacing batteries

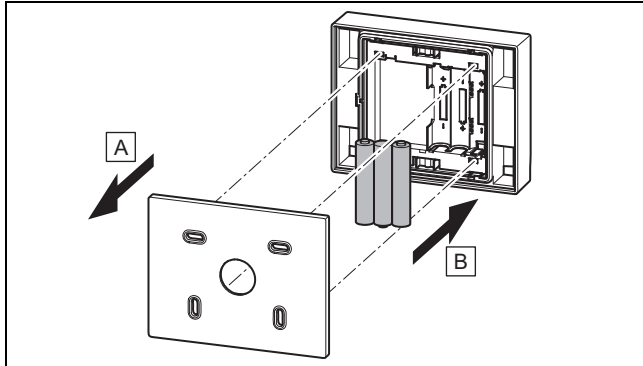

1. Remove the thermostat from the product bracket or remove the product stand from the thermostat.
2. Insert three new batteries (they must all be the same type). Pay attention to the correct polarity.
3. Only use AAA alkaline 1.5 V batteries. Do not use rechargeable batteries.
4. Place the thermostat back onto the product bracket or place the product stand back onto the thermostat. The thermostat or product stand audibly click into place.

4.10 Start screen

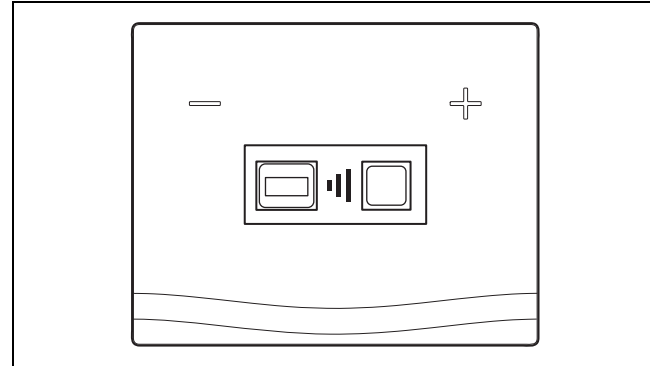

After you insert the batteries, the start screen is displayed. The start screen shows that the thermostat is searching for the communication unit.

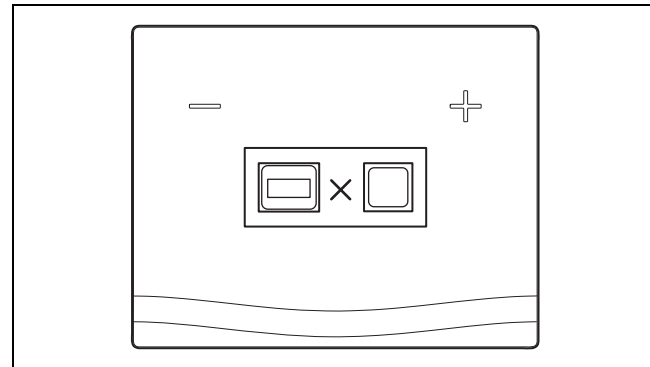

5 Troubleshooting

If the communication unit is not found (e.g. the distance between the thermostat and the communication unit is too great), the above display view is shown.

5 Troubleshooting

You can find an overview of the possible faults in the appendix.

Faults – Overview (→ Page 14)

6 Care and maintenance

6.1 Caring for the product



Caution.

Risk of material damage caused by unsuitable cleaning agents.

- ▶ Do not use sprays, scouring agents, detergents, solvents or cleaning agents that contain chlorine.
-
- ▶ Clean the surface of the product with a damp cloth and a little solvent-free soap.

7 Decommissioning

7.1 Permanently decommissioning the product

- ▶ Have a competent person permanently decommission the product.

8 Recycling and disposal

- ▶ The competent person who installed your product is responsible for the disposal of the packaging.



If the product is identified with this symbol:

- ▶ In this case, do not dispose of the product with the household waste.
- ▶ Instead, hand in the product to a collection centre for old electrical or electronic appliances.



If the product contains batteries that are marked with this symbol, these batteries may contain substances that are hazardous to human health and the environment.

- ▶ In this case, dispose of the batteries at a collection point for batteries.

9 Guarantee and customer service

9.1 Guarantee

We only grant a Vaillant manufacturers warranty if a suitably qualified engineer has installed the system in accordance with Vaillant instructions. The system owner will be granted a warranty in accordance with the Vaillant terms and conditions. All requests for work during the guarantee period must be made to Vaillant Service Solutions.

9.2 Customer service



To ensure regular servicing, it is strongly recommended that arrangements are made for a Maintenance Agreement. Please contact Vaillant Service Solutions for further details.

Vaillant Service Solutions: 03 30 100-31 43

Appendix

Appendix

A Faults – Overview

| Symbol | Meaning | Remedy |
|---|--|--|
|  | Batteries almost flat. | – Replace the batteries in the thermostat. |
|  | Batteries flat. | – Replace the batteries in the thermostat. |
|  | No connection to the communication unit. | – Reduce the distance between the thermostat and the communication unit. |

B Legal note

"Made for iPod", "Made for iPhone" and "Made for iPad" mean that an electronic accessory has been designed that was developed especially for the relevant connection to an iPod, iPhone or iPad, and for which the developer has certified that it complies with Apple's performance standards. Apple shall not be liable for the operation of this device or its compliance with the safety standards and regulations. Note that using this accessory with an iPhone may impair the radio performance.



0020212889_01 ■ 15.07.2015

Vaillant Ltd.

Nottingham Road ■ Belper ■ Derbyshire ■ DE56 1JT

Telephone 03 30 100-34 61 ■ Telephone (renewables) 02 07 022-09 28

Vaillant Service Solutions 03 30 100-31 43 ■ Spares Technical Enquiries 177 359 66 15

info@vaillant.co.uk ■ technicalspares@groupservice.co.uk

www.vaillant.co.uk

© These instructions, or parts thereof, are protected by copyright and may be reproduced or distributed only with the manufacturer's written consent.